

- Installation Guide -

VE118-SCA8 LGX-Type Panel with 8 SC/APC Couplers

1. GENERAL DESCRIPTION

1.1 Document Purpose

This document provides installation information for the Westell® VirtualEdge® VE118-SCA8 LGX®-type panel with 8 SC/APC-type couplers, which is typically installed in one LGX-type position of a Westell VirtualEdge mounting. The panel is shown in Figure 1.

- NOTE -

Hereafter, the VE118-SCA8 also may be commonly referred to as the "panel."

1.2 Document Status

Whenever this document is updated, the reason will be stated in this paragraph.

1.3 Product Purpose & Mounting

The VirtualEdge (VE) VE118-SCA8 is a panel which contains eight SC/APC couplers secured in an LGX-sized faceplate that can be installed in Westell VirtualEdge mountings. As shown in Figure 2 and Figure 3, this panel mounts in a VirtualEdge mounting or enclosure that contains LGX-sized cut-outs or positions. Two provided snap-in Nylatch® fasteners are used to secure the panel in the mounting. See Table 1 below for model numbers of specific Westell VirtualEdge mountings which accept the panel.

Model	# LGX positions	Description
VEUP-30	3	1-RU high, 3-LGX-position mounting with 12 empty Keystone ports and rear tray, for walls, 19" racks, or 23" racks.
VEUE-30	3	Wall-mount locking enclosure with separate Network and subscriber doors, 3 LGX positions (12 Keystone positions), fiber spool, and space for 2 fiber splice trays.
VECE-30	3	Wall-mount locking enclosure with one door, 3 LGX positions (12 Keystone positions), 4 SC couplers, fiber spool, fiber splice tray (space for 2), and special cable (stub-to-4 SC/UPC connectors).
31EVE-20	2	Outdoor NID enclosure with 2 LGX positions and 8 Keystone ports.

Table 1. Mountings for the Panel

- INSPECTION NOTE -

Visually inspect the product for damages prior to installation. If damaged in transit, immediately report the damage to the transportation company and to Westell (see Part 3 for telephone number).

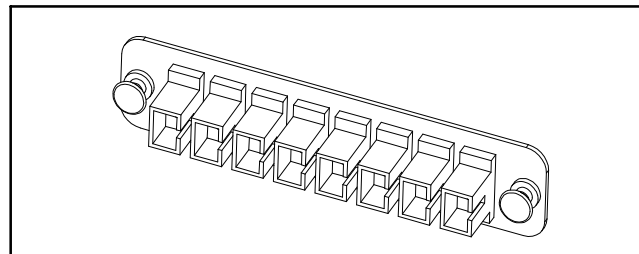

Figure 1. VE118-SCA8 Panel

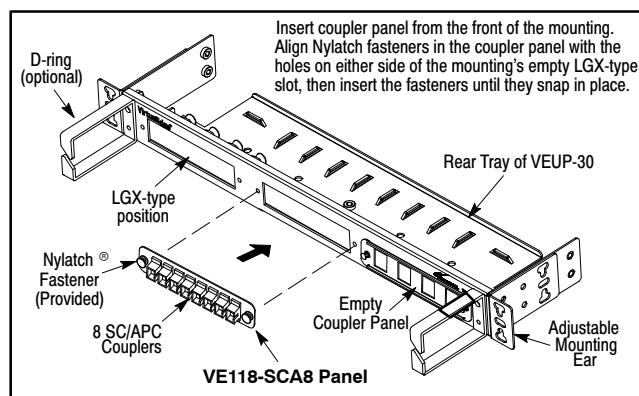

Figure 2. Installing VE118-SCA8 Panel in a VEUP-30

2. INSTALLATION

Always follow local company practices and procedures when installing equipment. If none exist, follow the steps below to install the panel. Consult Figure 2 and Figure 3 as needed while performing these steps.

- FIBER WARNINGS AND CAUTIONS -

Always follow proper fiber precautions whenever working with fiber.

Carefully clean up any shards and loose fiber pieces and avoid hand, skin, or eye contact with fiber shards.

Never look into the end of a live fiber strand and always wear protective eyewear.

Always observe proper fiber cable bend radius guidelines; never kink or excessively bend or loop fibers.

- Gather tools and supplies.** The following tools and supplies may be needed to install the panel.
 - VirtualEdge mounting with LGX®-type cut-out slots
- Align panel with the mounting.** Locate the predrilled holes at both ends of an empty LGX-type position in a VirtualEdge mounting. Align the Nylatch fasteners and holes at each side of the panel with the holes in the empty LGX position in the mounting.

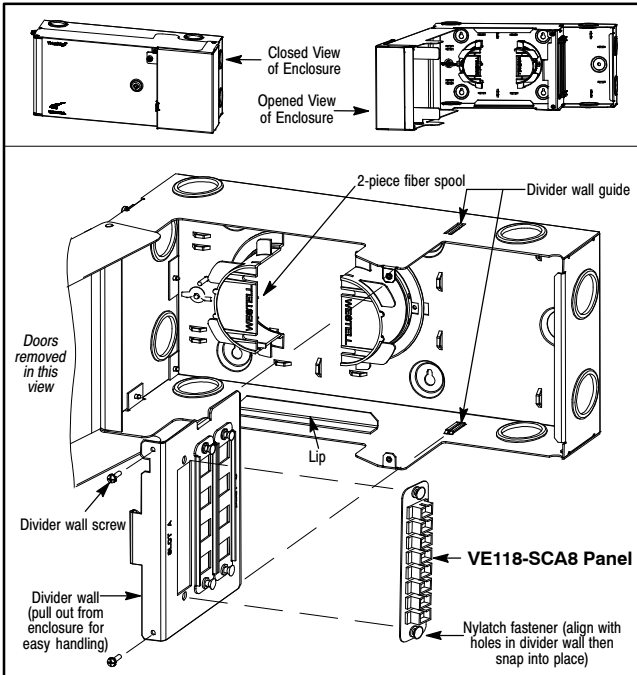

Figure 3. Installing Panel Inside a VEUE-30 Enclosure

3. **Secure panel with fasteners.** Insert the Nylatch® fasteners at both sides of the panel through the holes provided for them in the mounting or enclosure, and press or snap them into place (fasteners also can be easily pulled out to remove them).
4. **Test.** Attempt to move the panel to verify a snug fit.
5. **Route and connect cables.** Route then connect the SC/APC cables to the SC/APC couplers on the panel, per company practice. Connect “out” or downstream equipment to the front connectors of the panel, and “in” or upstream equipment to the rear connectors.
6. **Perform cable management.** Carefully and gently loop and manage any excess cable slack using the cable tie-downs on the mounting, or using any installed D-rings or front tray.

3. CUSTOMER & TECHNICAL SERVICES

If technical or customer assistance is required, contact Westell by calling or using one of the following options:

Voice: (800) 377-8766
email: global_support@westell.com

4. WARRANTY & REPAIRS

4.1 Warranty

Westell warrants this product to be defect free at shipment time, and warrants the product to be fully functional for the time period specified by the terms and conditions governing the product sale. Equipment repairs/modifications by unauthorized persons will void the warranty.

4.2 Repair and Return

Westell will repair or replace this unit without cost during the warranty period if the unit is defective for any reason other than abuse, improper use, or improper installation. To return defective equipment, first request a Return Material Authorization (RMA) number from Westell by calling or using one of the options shown below. Once an RMA number is obtained, return the defective unit (freight prepaid), along with a brief problem description, to the address we will provide to you when you contact us.

Voice: (630) 375-4457
email: rgmdept@westell.com

Westell will repair or replace faulty equipment beyond the warranty time for a nominal charge. Call Westell for details.

5. SPECIFICATIONS

The physical specifications are shown in Table 3.

To order panels, call the telephone number shown in Part 3 and please specify the panel part number shown in Table 2.

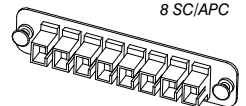
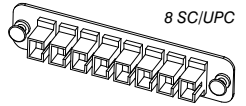
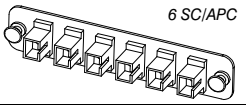
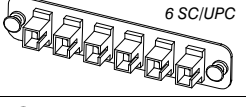
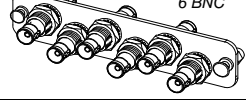
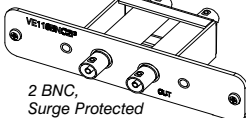
Part #	Description
A90-VE118SCA8	Westell® VirtualEdge® 8-coupler SC/APC panel. Includes two Nylatch fasteners. Mounts in empty LGX-position in a VirtualEdge mounting. 
Options, Accessories, and Additional Panels	
A90-VE118SCU8	Panel with eight SC/UPC couplers. 
A90-VE118SCA6	Panel with six SC/APC couplers. 
A90-VE118SCU6	Panel with six SC/UPC couplers. 
A90-VE118BNC6	Panel with six BNC couplers. 
A90-VE118BNC2P	Panel with two surge-protected BNC couplers. 

Table 2. Ordering and Option Information

Feature	U.S.	Metric
Height	1.12 inch	2.8 cm
Width	5.1 inches	13 cm
Width, between mounting holes	4.64 inches	118 mm
Depth	1.1 inches	2.8 cm
Operating Temperature	-40° to 149°F	-40° to +65°C
Humidity	0 to 95% (non-condensing)	

Table 3. VE118-SCA8 Physical Specifications