

# Westell® | CS19-BBU-004

12/24-Hour NFPA Compliant Battery Back-Up Enclosure



## General Information

Westell's CS19-BBU-004 series of public safety battery backup units are designed to provide main power and uninterruptible backup power for any 12 VDC public safety bi-directional amplifier (BDA) system. The Westell CS19-BBU-004 series can maintain full continuous operation of a BDA for 24 hours or more depending on battery installed.

The CS19-BBU-004 series provides an integrated power, battery charger and alarm monitor system. The power system provides up to 175W of power to the BDA. The alarm system has auxiliary connections to the BDA for remote monitoring. Electronics and batteries are housed in a NEMA 4 enclosure.

The CS19-BBU-004 provides full NFPA 72/1221/1225/UL2524 indicator support with Westell 12 VDC BDAs.

Lead-acid batteries are ordered separately and will determine the length of battery backup time.

## Product Highlights

- 24-hour back-up capable
- NFPA 1221/2524 compliant
- AC input, 12 VDC output
- Power system UL 60950-1 listed
- NEMA-4 protection
- -30°C to +50°C operation
- On off AC/DC switch
- Optional emergency power off (EPO) switch

## Applications

- Indoor/outdoor
- NFPA battery backup for BDAs
- Integrated Power and alarm cable assembly for Westell BDA
- Watertight glands

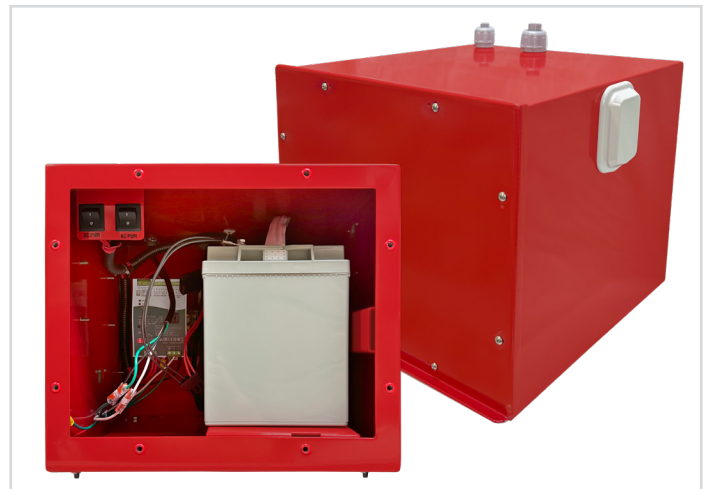

CS19-BBU-004

## Specifications

Input Voltage	85 - 125 VAC
Input Frequency	45 - 66 Hz
Typical Input Current	0.8A/108 VAC
Output Voltage	12 VDC
Maximum Output Power	175W max
Environmental	-30°C to +50°C
Dimensions (H x W x D)	17.5" x 16.6" x 15.5"
Weather Resistance	NEMA-4
UL	60950-1, 2524
Mounting	Wall
Cable Entries	1 @ 3/4 ALM, DC; 1 @ 1/2 conduit

## Ordering information

Part Number	Description
CS19-BBU-004	NG-BBU NEXT GEN CHRGR-BATT BACKUP NEMA 4

## Batteries, Available Separately

Battery Recommendation for Westell Class A/B BDAs		Qty Req.
CS19-BAT55AHSLA	55AH, 12V, SLA battery for CS19-BBU-004 series	1
CS19-BAT100AH31	100AH, 12V battery for CS19-BBU-004 series	1



# Westell® | CS19-BBU-004

12/24-Hour NFPA Compliant Battery Back-Up Enclosure



## Mechanical Drawings - Inches [mm]

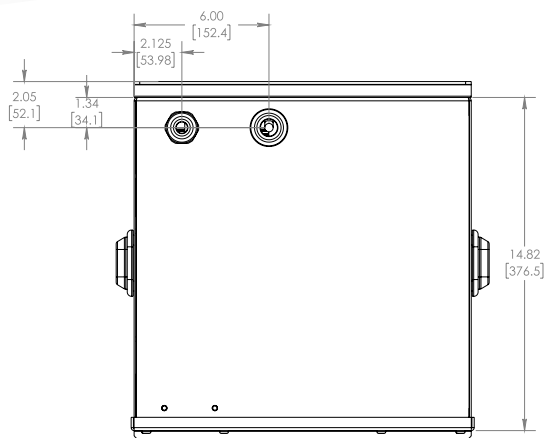

Top of Cabinet

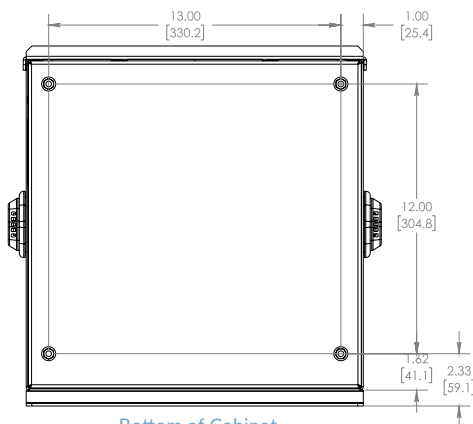

Bottom of Cabinet

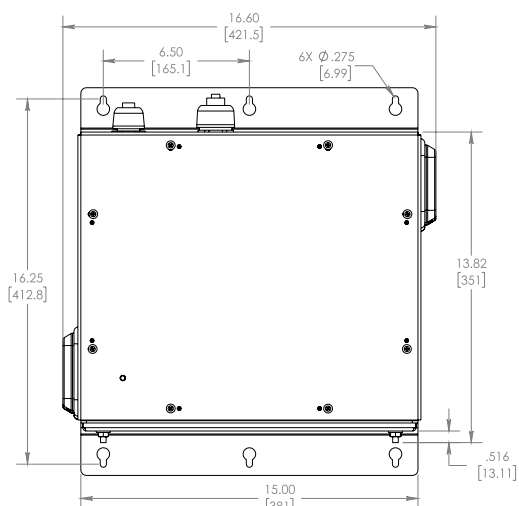

Front of Cabinet

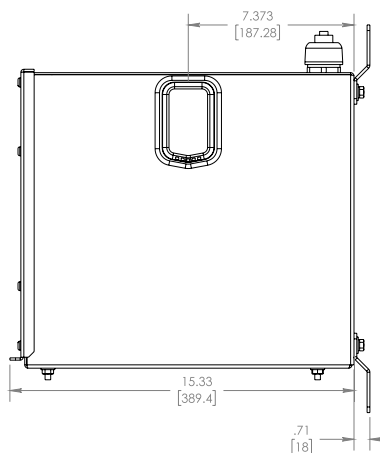
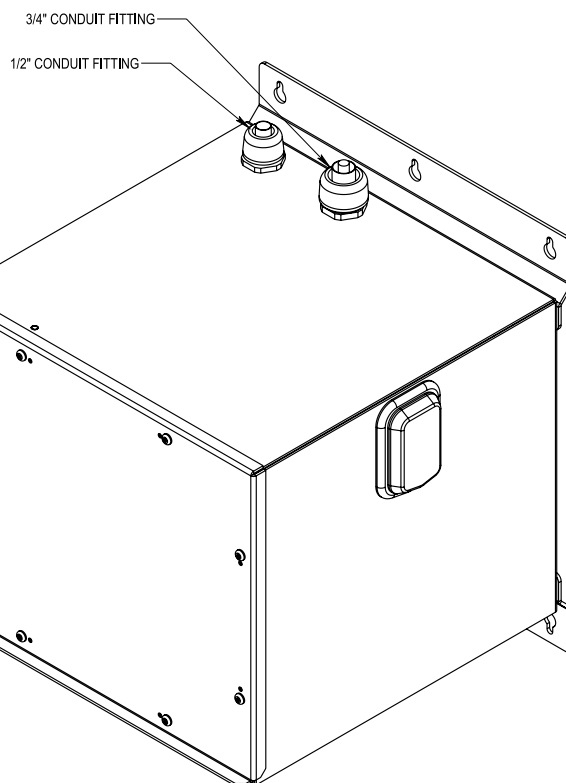

Side of Cabinet

